

BRAKE ENERGY RECOVERY UNIT

IITM Technology Available for Licensing

Problem Statement & Unmet Need

- The **kinetic energy** in automobiles is **wasted** significantly in the form of **Heat** during the conventional **braking process** in a vehicle.
- If the vehicle battery is considered for **storing the energy recovered during deceleration**, the battery used herein needs to have a sufficiently lower state of charge **to accept the recovered brake energy**.
- Further, the vehicle battery requires the **capability to absorb the brake energy in a short time** and operate reliably with frequent charge-discharge cycles.
- Therefore, there is a need for a brake energy recovery unit for an engine to detect a brake event and initiate a brake energy recovery procedure.

Technology Category/ Market

Electrical Engineering: Control unit to initiate Brake energy recovery of an automobile;

Industry: Automobile, Transportation

Applications: Brake energy recovery unit in a two/three/four-wheeler vehicle(s);

Market: Automotive energy recovery system market was valued at \$22.4 billion in 2020 and is estimated to reach **\$45.5 billion by 2030**, growing at a CAGR of **7.4%** from 2021 to 2030.

Technology

- The Brake energy recovery unit comprises an **alternator and a control unit** to detect a Braking event and initiate a Brake energy recovery procedure.
- The alternator, fixed in an engine, is connected to either a load or a battery through the first switch.
- Moreover, the alternator is connected to super-capacitor through a second switch; and said super-capacitor is connected to the load or the battery through a unidirectional DC-DC converter, wherein the **control unit is configured to control said electronic device(s)**.
- The Brake energy recovery unit determines if the energy is recovered by analysis of a vehicle speed, and **recovers the kinetic energy to form electric energy to store in the super capacitor**.

- The Brake energy recovery unit further includes a plurality of sensors fixed at various positions in the vehicle parts to identify the various conditions for transferring the energy from the alternator to super-capacitor (**FIG 1**)

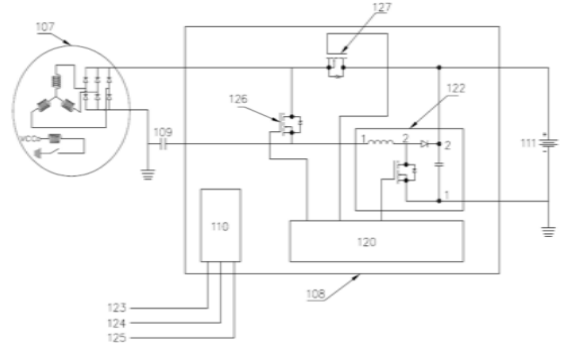

Fig. 1: Illustrates the brake energy recovery unit

Intellectual Property

IITM IDF No. 1168

IN Patent No.: 418648 (Granted)

Key Features / Value Proposition

- The use of recovered brake energy can be offered **significant fuel savings** and said unit provides the facility of **reducing the wear and tear of the brakes**.
- Dynamic properties and **economical efficiency** of the automobile are **improved with service life & brake security** of a vehicle storage battery is prolonged.
- The brake energy recovery unit allows the realization of **regenerative braking for automobiles** with **minimum modification** in electric parts of vehicles with a **simple control strategy** leading to a **low-cost solution**.

TRL (Technology Readiness Level)

TRL- 3; The Proof of Concept Stage.

Research Lab

Prof. SRIRAMA SRINIVAS

Dept. of Electrical Engineering, IIT Madras

CONTACT US

Dr. Dara Ajay, Senior Manager
Technology Transfer Office,
IPM Cell- IC&SR, IIT Madras

IITM TTO Website:
<https://ipm.icsr.in/ipm/>

Email: smipm-icsr@icsrpis.iitm.ac.in

sm-marketing@imail.iitm.ac.in

Phone: +91-44-2257 9756/ 9719