

SPHERICAL ROBOT FOR INTERNAL INSPECTION OF PIPELINES

IITM Technology Available for Licensing

Problem Statement

- Pipelines are hollow cylindrical conduits used for transportation of fluids, i.e., gases or liquids. Depending upon the industry, distance, or the fluid transported, **pipelines may be buried under ground, exposed to atmosphere**, or submerged under water.
- Exposure to any extreme or **harsh conditions could weaken the integrity of the pipeline structure**, and may undergo corrosion or damage causing leakage.
- In some instances, pipelines may also develop blockages, gas pockets, pitting, sedimentation, etc. Hence, many industries that rely heavily on pipelines, such as petroleum, natural gas, manufacturing companies, and the like, could face huge losses.
- More importantly, such scenarios could **lead to discharge of pilferage** that may be potentially dangerous to the environment.
- Therefore, **continuous maintenance of pipelines remains a major concern** and large resources are allocated for this purpose.

Technology Category/ Market

Category - Robotics, Non-destructive evaluation (NDE)

Applications - Non destructive evaluation & testing, Pipeline inspection, Oil & Gas Pipelines, Water Pipelines

Industry - NDT, Oil & Gas, Marine, Defense

Market - The Pipe Inspection Robot market is anticipated to attain a of US\$ 3 Billion by 2023-end. Global demand for pipe inspection robot is expected to rise at a **CAGR of 15.8% US\$ 12 Billion in 2033.**

Key Features / Value Proposition

1. The disclosed robotic device is a passively propelled spherical robot that **can be used for inspecting piggable and non-piggable pipelines**, ferromagnetic and non-ferromagnetic pipelines, which are widely used in industries.
2. The device **can operate without shutting down** the entire plant. This allows inspectors to inspect a pipeline more frequently at a **reduced cost**.
3. The device is relatively simpler and easier to manufacture and use, and therefore, is inexpensive and has good market potential for inspection of pipelines especially for oil, gas, and water pipelines.

Intellectual Property

- IITM IDF Ref. 1824
- IN 437412 - Patent Granted
- PCT/IN2019/050134
- National Phase - Nigeria; RP. F/P/2021/56 - Patent Granted

FIG. 1. illustrates an exploded view of a modular device for internal inspection of pipelines.

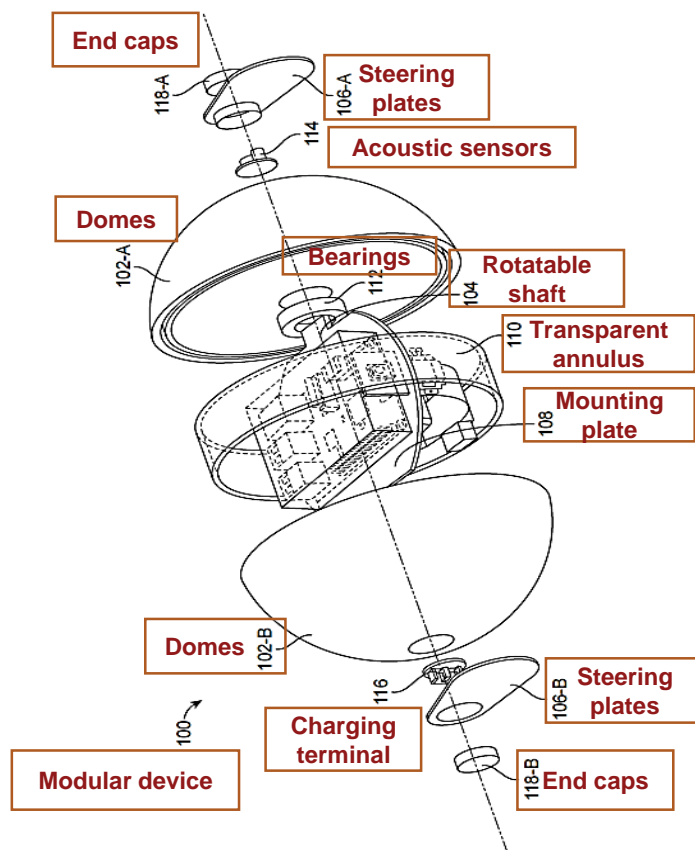

TRL (Technology Readiness Level)

TRL - 7, System prototype demonstration in operational environment.

Research Lab

Prof. Krishnan Balasubramanian,
Prof. Prabhu Rajagopal,
Dept. of Mechanical Engineering, IIT Madras

CONTACT US

Dr. Dara Ajay, Head TTO
Technology Transfer Office,
IPM Cell- IC&SR, IIT Madras

IITM TTO Website:

<https://ipm.icsr.in/ipm/>

Email: headtto-icsr@icsrpiis.iitm.ac.in

tto-mktg@icsrpiis.iitm.ac.in

Phone: +91-44-2257 9756/ 9719

Industrial Consultancy & Sponsored Research (IC&SR)

Technology

The present invention relates to systems and devices for internal inspection and survey of fluid filled pipelines using sensors. The modular robotic device for internal inspection of pipelines includes: (Fig. 1, 2, 3).

- 1 • A transparent annulus sealed between a pair of domes to form an outer shell of spherical or ellipsoidal shape.
- 2 • A rotatable shaft mounted about an axis of the outer shell and coupled to a pair of steering plates.
- 3 • The steering plates are configured to steer the device into a rotational motion along the fluid flow, wherein the shaft rotates independent of the outer shell.
- 4 • A stabilization assembly is housed in the shell to dampen oscillations during motion.
- 5 • A visual sensor is mounted on the mounting plate and configured to capture images of internal defects of the pipeline as visual data through the transparent annulus.
- 6 • An acoustic sensor is configured to detect leaks using acoustic signals as acoustic data.
- 7 • A processing unit is mounted on the mounting plate, wherein it is configured to log the visual and acoustic data for inspection of the inner surface of the pipeline.

FIG. 2. illustrates a schematic diagram of the electronic modules of the modular device in communication with a remote system.

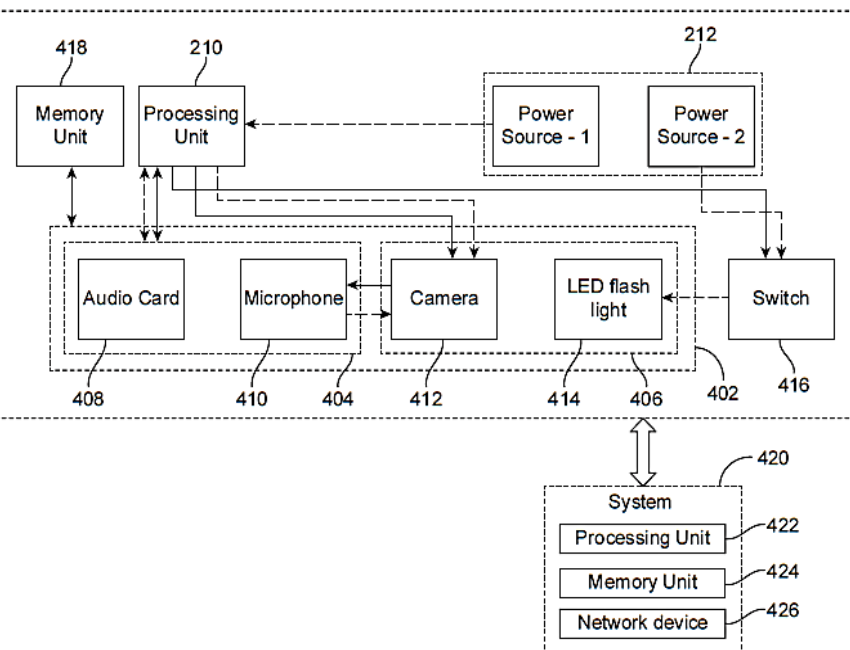
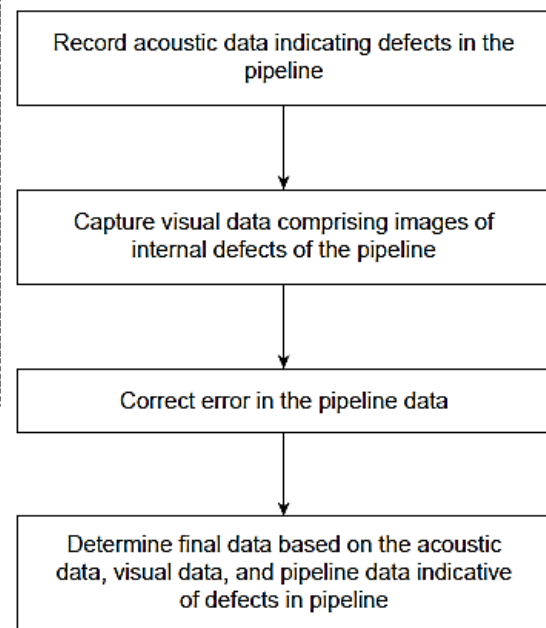

FIG. 3. illustrates a method for visual and acoustic inspection of pipelines containing a moving fluid.



CONTACT US

Dr. Dara Ajay, Head TTO
Technology Transfer Office,
IPM Cell- IC&SR, IIT Madras

IITM TTO Website:
<https://ipm.icsr.in/ipm/>

Email: headtto-icsr@icsrpis.iitm.ac.in
tto-mktg@icsrpis.iitm.ac.in

Phone: +91-44-2257 9756/ 9719